

IMPLEMENTATION OF THE RAPID PROTOTYPING TECHNOLOGY FOR MEDICAL AND BIOMEDICAL ENGINEERING

Prof. ing. Gh. Ion Gheorghe, PhD, Ing. Ciobota Nastase-Dan, PhD candidate,

National Institute of Research and Development for Mechatronics and Measurement Techniqu e

Prof. Igor Drstvensek, PhD

University of Maribor, Faculty of Mechanical Engineering, Slovenia

***Abstract.** In this paper will be presented a new technology, using new materials especially designed for complex geometries, extensively used in research -development and innovation area. Even highly complex geometries are created directly from 3D CAD data, fully automatically, in just a few hours and without any tooling. It is a net-shape process, producing parts with high accuracy and detail resolution, good surface quality and excellent mechanical properties.*

1. INTRODUCTION

In this paper will be presented a new technology, using new materials especially designed for complex geometries, extensively used in research-development and innovation area. In order to do this we will go through presentation of the basic principles for the rapid prototyping technology, materials and capabilities.

This technology use the EOSINT M270 machine, which is an laser -sintering system for the production of tooling inserts, prototype parts and end products directly in metal.

Laser-sintering is the key technology for e-Manufacturing.

The implementation of this technology took place on Biomechatronics Department in National Institute of Research and Development for Mechatronics and Measurement Technique, Bucharest, Romania.

The Laser-Sintering System for metal powder is in conformity with the provisions of the European Union as follows:

- Machinery Directive 98/37/EC, Annex II A;
- Low Voltage Directive 73/23/ECC;
- EMC Directive 89/336/ECC.



NATIONAL INSTITUTE OF RESEARCH AND DEVELOPMENT FOR MECHATRONICS AND MEASUREMENT TECHNIQUE

We were the first Romanian entity to install DMLS equipment, and yearly demand for laser -sintering services has increased. We expect interest in titanium parts to follow the same strong demand curve.

Since 2007, INCDMTM work to identify product applications and introduce our systems to the manufacturing industry.

With the purchase of this new titanium-based system, INCDMTM stays among the leading suppliers who are willing to explore DMLS (Direct Metal Laser Sintering) and the breakthroughs it holds for innovative companies.

The EOSINT M 270 system uses laser-sintering to additively manufacture parts layer-by-layer. A range of metal materials is available, including steels, cobalt- and nickel-based superalloys and titanium alloys. EOS Titanium Ti64 is a pre-alloyed Ti6AL4V alloy with excellent mechanical properties and corrosion resistance, low specific weight, and biocompatibility.

Parts built from this alloy can be machined, spark-eroded, welded, micro shot-peened, polished and coated as needed. Typical uses include dental, orthopedic, and airframe applications.



We are also very pleased to become cooperation with one of the EU country, namely with Slovenia.

Prof. Dr. Igor Drstvensek from University of Maribor, Faculty of Mechanical Engineering established a wide cooperation between mechanical and medical research fields and develop several methods for custom

implant production that helped surgeons to shorten the operating time and rise the outcome probabilities with better preoperative planning.

Together, we want to create an excellence research centre with a favourable climate for research and development of new technologies linked to medical imaging, 3D geometric modelling of osteo-articular structures, computer-assisted surgery and quantitative assessment of orthopaedic and surgical corrective methods.

Metal parts directly from CAD data

A number of different materials are available for use with EOSINT M systems, offering a broad range of e-Manufacturing applications. EOS CobaltChrome MP1 is a multi-purpose cobaltchrome-molybdenum-based superalloy powder which has been optimized especially for processing on EOSINT M 270 systems. Other materials are also available for EOSINT M systems, including a special-purpose cobalt-chrome-molybdenum-based superalloy for dental veneering application, and further materials are continuously being developed - please refer to the relevant material data sheets for details.

The ability to produce such parts very quickly enables flexible and economic manufacture of individual parts or batches, which in turn enables design or manufacturing problems to be identified at an early stage of product development and time to market to be shortened.

This new technology is used in top domains of engineering and medicine, both for civil and military purposes. The most advanced engineering entity, National Aeronautics and Space Administration (NASA), use the EOSINT M270 machine, Titanium Version.

2. THE MECHANICAL AND OPTICAL UNIT PRINCIPLES OF THE SLS MACHINE

Mechanical Unit

The mechanical unit contains the following components:

1. Recoater
2. Dial gauge with bracket
3. Building platform
4. Feeler gauges (graduation 0.05 mm)
5. Measuring strip
- A. Adjusting motor for adjusting the Y-axis
- B. Adjusting motor for adjusting the X-axis

The mechanical unit contains the following components:

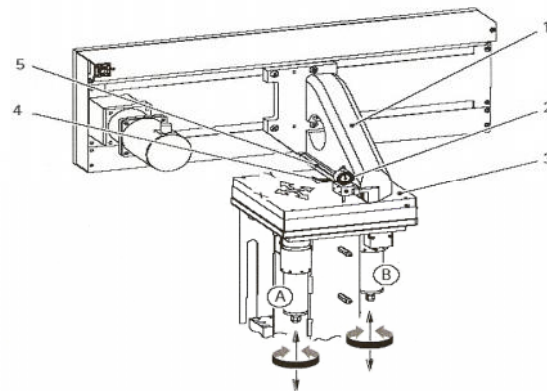

Figure 1. EOSINT M – mechanical unit

Optical Unit

The optical unit contains the following components:

1. Scanner with protective covers
2. Adjusting knob BEAM EXPANDER ADJUSTEMENT

3. Beam expander optics
4. Collimator with holder and protective cover
5. Laser fibre optic

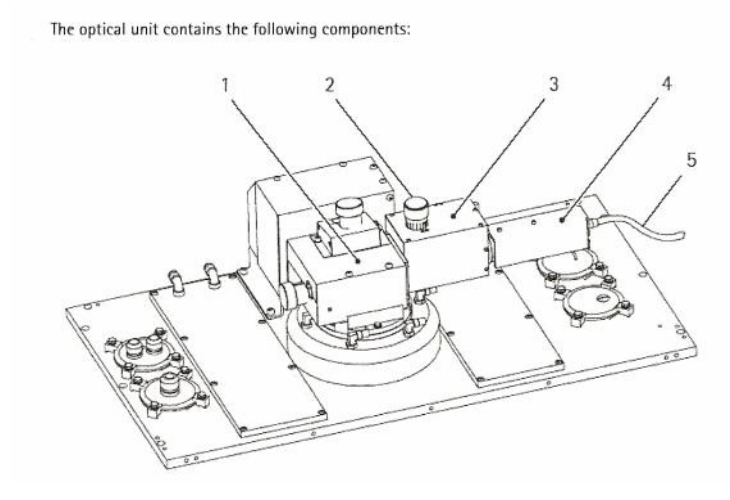

Figure 2. EOSINT M – optical unit

3. MECHANICAL AND BIOCOMPATIBILITY PROPERTIES

This is only a short list, because constantly are developed new powders with increased mechanical, physical and thermal properties.

Material name	Material type
DirectMetal 20	Bronze-based mixture
DirectSteel H20	Steel-based mixture
EOS MaragingSteel MS1	18 Mar 300 / 1.2709
EOS StainlessSteel 17-4	Stainless steel 17-4 / 1.4542
EOS CobaltChrome MP1	CoCrMo superalloy
EOS Titanium Ti64*	Ti6Al4V light alloy
EOS Titanium TiCP*	Pure titanium

Table 1. Categories of metal powders that can be used

Titanium alloys offer a unique combination of properties for many biomedical applications.

Summary of important biomedical properties:

- Excellent corrosion resistance, biocompatibility and bioadhesion ;
- Titanium and its alloys are used for many biomedical and dental applications (implants, screws, crowns...).

Property	Stainless steel	Titanium alloys	CrCo alloys	Nb/Ta
Corrosion resistance	0	++	+	++
Biocompatibility	0	++	+	++
Bioadhesion	0	++		
Price	++	+	+	-

Table 2. Summary of important biomedical properties

Titanium alloys offer a unique combination of properties for many engineering applications .

Summary of important engineering properties :

- Light weight material with high specific strength (strength per weight)
- Ti6Al4V with high strength also at elevated temperatures

The combination of mechanical properties and the corrosion resistance is the basis for applications in Formula 1 and aerospace.

Various grades of Titanium (alloys) are commonly used in industrial applications.

Material name	Composition	Typical applications
CP Ti grade 1	Ti; O <0.18%; N <0.03%	Medical and dental
CP Ti grade 2	Ti; O <0.25%, N <0.03%	Medical and dental, chemical industry
CP Ti grade 3	Ti; O <0.35%, N <0.05%	Medical and dental
CP Ti grade 4	Ti; O <0.40%, N <0.05%	Medical and dental
Ti6Al4V (grade 5)	Ti; Al 6%; V 4%; O <0.20%, N <0.05%	Aerospace, motor sport, sports goods, medical and dental
Ti6Al4V ELI	Ti; Al 6%; V 4%; O <0.15%, N <0.05%	Medical and dental

Table 3: Summary of the most important Ti materials

CP = commercially pure, ELI = extra -low interstitials

Uses of CAD and Rapid Prototyping in medicine

Combined with traditional CT scanning techniques rapid technologies (prototyping and tooling) can be used as instruments for better (three-dimensional) visualization, simulation of procedures and treatment of patients.

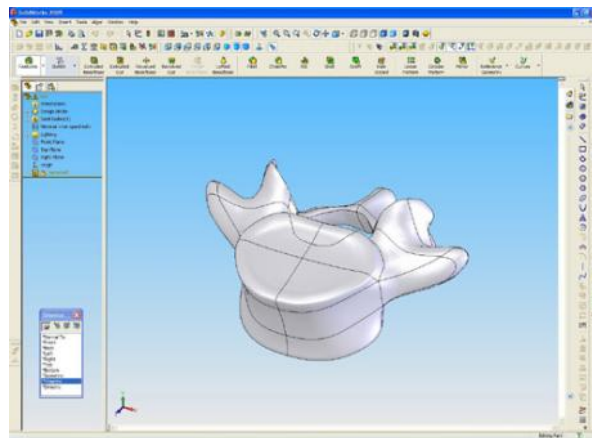

Figure 3. Parametric model in 3D CAD - SolidWorks

The CAD models, virtual model of a human body or a part of it can be used to study the problematic area before the actual operation starts. This is especially important in cases where functionality of the body part has to be re-established (orthopaedic surgery). Besides the continuous flow and other FEA methods that are used to calculate required mechanical and physical properties of the implant, the virtual models can also be used to study the surgical procedures, like directions of implantation, required preoperational treatments and preparations, etc.

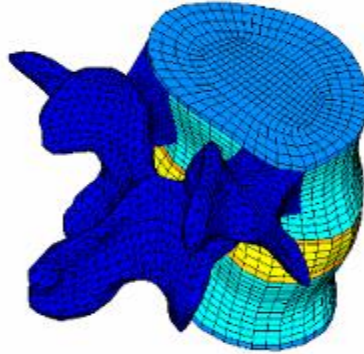

Figure 4. CAD model on human vertebrae used for FEM analysis

The easiest way to reconstruct the structure of a patient's bones is to use those CT images that already exist from previous treatments of the patient. A set of CT images can be converted into a three-dimensional, digital model using one of the available conversion software, such as: Mimics (Materialise), RapidForm (Inus Technology), 3D doctor (Able Software), Amira (Mercury Computer), or others. The input to this software is usually in the form of DICOM files and output is predominantly STL (Standard Tessellation Language), which can be directly used in most RP technologies to produce real models.

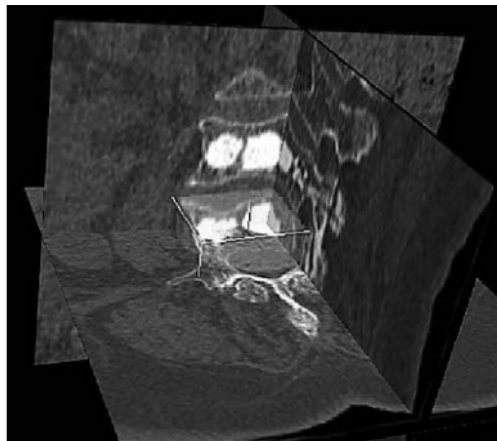

Figure 5. CT scan used for analysis

Three dimensional reconstruction of DICOM images in a form of STL file can be further manipulated by several CAD software. The usual 3D modelers based on parametric, volume modeling techniques are

not very well suited to the task. Newer versions of these software packages (SolidWorks 2008, Delcam, etc.) enable manipulation of triangulated surface files, but using dedicated software, known from Reverse Engineering fields, such as Magics (Materialise), RapidForm, PolyWorks (InnovMetric), or others is much more effective in terms of time and effort. Using these software and STL models of scanned body parts, missing tissue can be modelled and saved as new STL files. These can be further processed or used for the production of real implant models by means of RP or RM technologies. CAD modelling of the implant was performed using several reverse engineering software packages.

Another interesting idea is to use a combination of CT and RMN images.

4. CONCLUSIONS

The functional and design capabilities of a metallic implant material are important with respect to the metal's ability to be formed, machined, and polished. An implant metal must be capable of being utilized with state-of-the-art metallurgical techniques. In addition, the implant device must remain functional during its expected performance life; it must not be degraded with time in the body through fatigue, fretting, corrosion, or impact loading. Titanium and its alloys meet all of these requirements.

The principles of design, selection of biomaterials and manufacturing criteria for orthopedics implants are, basically, the same as for any other product that must be dynamically stressed. However, even the replacement of human tissues with materials similar in shape and density seems tempting, in fact this is much difficult task to undertake. That is because the living tissue has some extraordinary characteristics including the capacity of remodeling both micro structural and macrostructural under the different directions loads.

Orthopedics will emerge as the single most promising source of future investor returns in healthcare, given the confluence of demographics, technology and global expansion. While other healthcare sectors such as cardiovascular devices, cancer or biotech may have been more lucrative in the past, what the American Association of Orthopedic Surgeons (AAOS) calls the "Decade of Orthopedics" provides the best opportunity for future investor profits in healthcare.

A number of elements will create this opportunity for the next ten years:

- Increased life expectancies, which is a powerful demand driver that uniquely favors orthopedic devices.
- Technological innovation, which will change the entire complexion of the industry.
- Attractive industry economics and profitability.
- Combined, these elements will cause the industry to grow more than twofold, from \$30 billion per year to \$65 billion in the coming decade, resulting in as much as \$40 billion of potential investor profits.

This combination of factors supports sustained, attractive industry valuations.

We must understand that science and innovations are keys to SUCCESS.

5. REFERENCES

- [1] Bannon, B. P., and Mild, E. E., „**Titanium Alloys for Biomaterial Application: An Overview,**” Titanium Alloys in Surgical Implants, ASTM STP 796, H. A. Luckey and Fred Kubli, Jr., Eds., American Society for Testing and Materials, 1983, pp. 7 -15
- [2] Ciobota N.D., Titanium and Titanium Alloys for Biomedical and Industry Applications, National Institute of Research and Development for Mechatronics and Measurement Technique, Bucuresti, International Conference 6th Workshop on European Scientific and Industrial Collaboration on promoting Advanced Technologies In Manufacturing WESIC’08, Bucharest 25 -26 September 2008
- [3] Euro-Titan Handels AG, Solingen, Germany
- [4] Handzettel, EOS GmbH, 02-07, MS, M_ Standard_en
- [5] Igor Drstvensek, Natasa Ihan Hren, Tadej S trojnik, Tomaz Brajljeh, Bogdan Valentan, Vojko Pogacar, Tjasa Zupancic Hartner., „ **Applications of Rapid Prototyping in Cranio -Maxilofacial Surgery Procedures,**” International Journal of Biology and Biomedical Engineering , Issue 1, Volume2, 2008, pp. 29-38
- [6] Installation Conditions – EOSINT M 270, ED.01.08, 9212-0041, EOS GmbH – Electro Optical Systems
- [7] Material data sheets – EOSINT M 2x0, EOS GmbH – Electro Optical Systems, Robert-Stirling-Ring 1, D-82152 Krailling / München
- [8] MCP HEK Tooling GmbH, Selective Laser Melting Technology, www.mcp -group.de
- [9] http://www.healthpointcapital.com/about_us/
- [10] http://en.wikipedia.org/wiki/Titanium_alloy
- [11] <http://www.eos.info>
- [12] <http://www.pddnet.com/news-eosint-m-270-system-purchased-for-titanium-in-n-america-052209/>